

CAD FILE:

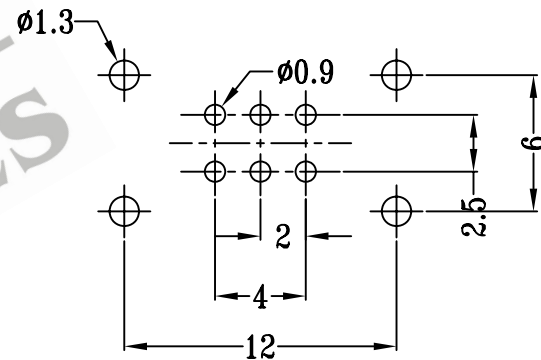
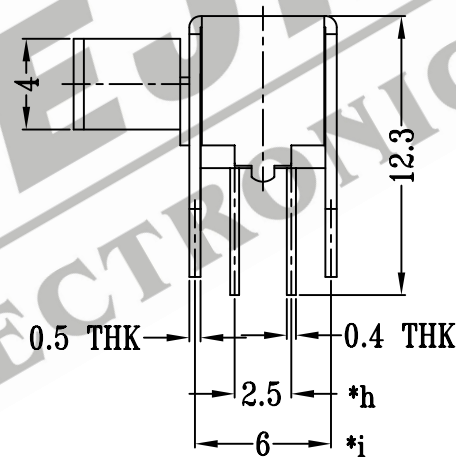
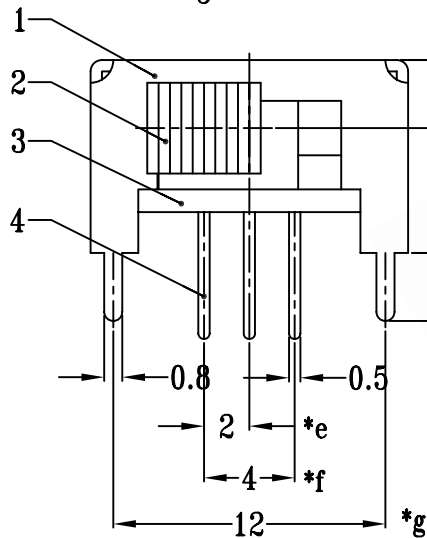
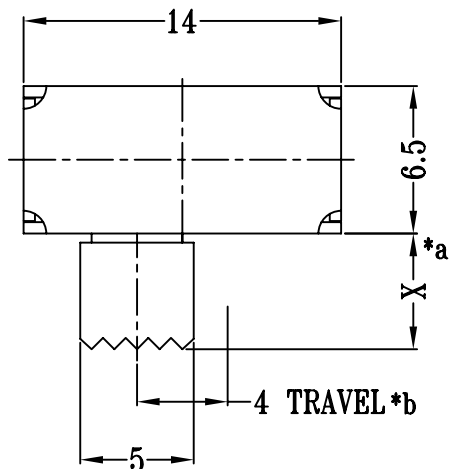

SCHEMATIC(SHORTING)

P.C.B LAYOUT

注:带"*"表示关键尺寸(9个)

NO.	PARTS	MATERIALS	Q'TY	FINISH	TOLERANCE UNLESS SPECIFIED	SHENZHEN XIEJIA ELECTRONICS CO.,LTD.				
8										
7	CONTACT CLIP	PBS C5210R-EH	2	Ag CLAD						
6	SPRING	STEEL WIRE	1	NATURAL	WITHIN: 1.5mm±0.1mm	ISSUE	DATE	DESCRIPTIONS OF REVISION		APPD.
5	STEEL BALL	STEEL	1	NATURAL	OVER : 1.5mm±0.2mm					
4	TERMINAL	BRASS STRIP	6	Ag PLATED OVER Ni PLATED	TITLE : HORIZONTAL SLIDE SWITCH		UNIT : mm	DRWG NO.: XJ-DR-SK22H14-00		
3	BASE	PHENOLIC RESIN	1	NATURAL	MODEL: SK-22H14		SCALE: 3:1	DWN.	ZHOUYU	2008-2-15
2	KNOB	POM	1	BLACK				CHK'D	FANGYING	2008-2-15
1	FRAME	STEEL STRIP	1	Ni PLATED	ALL MATERIALS MUST BE COMPLIANT TO ROHS		APPD.	KANGXINAN	2008-2-15	